



Overall Length

| TB SERIES, SMALL TANK SCREWPLUG HEATERS | | | | | | | |
|---|-------|----------------------------|--------|-----------|-----------|-----------|---------------------------|
| WATTS | VOLTS | OVERALL LENGTH In./(mm) | NPT | 304 SS | 316 SS | TITANIUM | SHIP WGT. Lbs./(kg) |
| 500 | 120 | 8 | 1-1/4" | FTB.5108 | STB.5108 | TTB.5108 | 8 |
| | 240 | (205) | | FTB.5208 | STB.5208 | TTB.5208 | (4) |
| 1000 | 120 | 10 | 1-1/4" | FTB1110 | STB1110 | TTB1110 | 10 |
| | 240 | (255) | | FTB1210 | STB1210 | TTB1210 | (4.5) |
| 1500 | 120 | 14 | 1-1/4" | FTB1.5114 | STB1.5114 | TTB1.5114 | 14 |
| | 240 | (355) | | FTB1.5214 | STB1.5214 | TTB1.5214 | (6.5) |
| 2000 | 120 | 17 | 1-1/4" | FTB2117 | STB2117 | TTB2117 | 17 |
| | 240 | (430) | | FTB2217 | STB2217 | TTB2217 | (8) |

Single phase only.

Product Features and Benefits:

- ◆ **SUPERIOR CHEMICAL RESISTANCE:** Materials available for use in most aqueous alkaline, plating solutions and rinse tanks. Check solution recommendation chart or with your chemical supplier for proper sheath material selection.
- ◆ **RUGGED CONSTRUCTION:** Heavy wall metal sheaths and screwplug available in:
 - Steel.
 - 304 stainless steel.
 - 316 stainless steel.
 - Titanium.
- ◆ **OUTSTANDING PERFORMANCE:** Watt densities of 40 watts per square inch (6.2 w/cm²) ensure long service life.
- ◆ **CORROSION RESISTANT HEAD:** Vapor tight, flame retardant polypropylene terminal enclosure with 3-foot (.9m) flexible PVC liquid tight conduit.
- ◆ **SAFETY FEATURES:**
 - Grounded construction.
- ◆ **CERTIFICATIONS:** UL and CE.
- ◆ **SIZES:** 500 watts to 2,000 watts.
- ◆ **VOLTAGES:** 120 or 240 volts. 208, 380, 415, 480, 600 and other voltages available. Single phase only.
- ◆ **OPTIONS AVAILABLE (consult factory):**
 - Special configurations and lengths.
 - Explosion resistant enclosures.
 - Longer wire and conduit lengths.
 - Lower watt densities for highly viscous solutions.
 - Temperature and level controls sized to match the heater.

DIMENSIONS

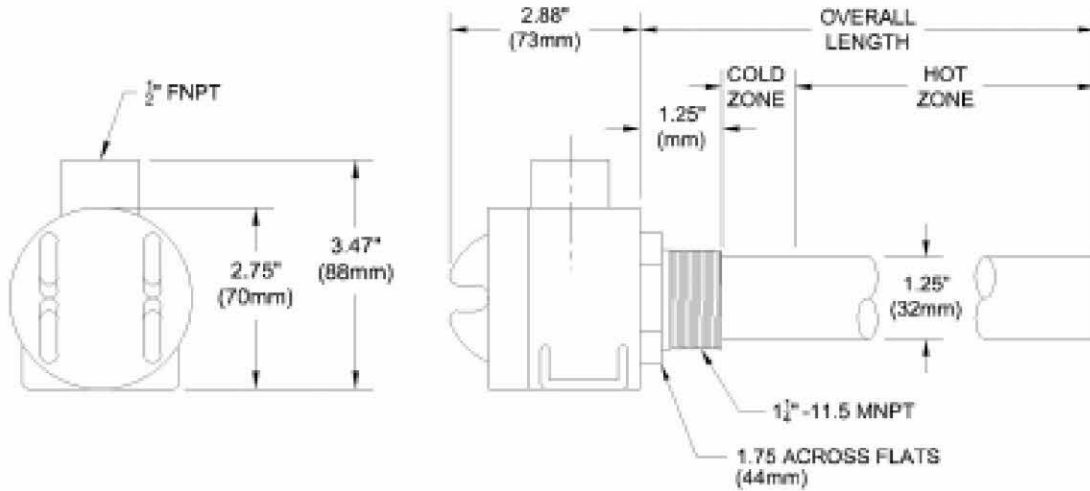

1 1/4" TUBULAR SCREW PLUG HEATER ORDERING INFORMATION

| Series | Wattage | Voltage | Length (in.) | Options | Wire and Conduit Length |
|---|---|--|---|---|-------------------------|
| <div style="border: 1px solid black; padding: 5px; margin-bottom: 5px;"> .5 = 500 1 = 1000 1.5 = 1500 2 = 2000 </div> <div style="border: 1px solid black; padding: 5px;"> FTB = 304 stainless steel STB = 316 stainless steel TTB = titanium </div> | <div style="border: 1px solid black; padding: 5px; margin-bottom: 5px;"> 1 = 120 2 = 240 4 = 480 -208 = 208 -380 = 380 -415 = 415 </div> | <div style="border: 1px solid black; padding: 5px; margin-bottom: 5px;"> 8 = .5kW 10 = 1kW 14 = 1.5kW 17 = 2kW (custom lengths available) </div> | <div style="border: 1px solid black; padding: 5px; margin-bottom: 5px;"> single phase power only -X = any special configuration not called out in the part number (specify in clear text) </div> <div style="border: 1px solid black; padding: 5px;"> no designator = 36" length standard, specify variations from standard Ex: -X84 = 84" </div> | <div style="border: 1px solid black; padding: 5px; width: 100px;"> Wire and Conduit Length </div> | |

ORDERING EXAMPLE:

FTB2117

304 stainless steel, 2,000 watts, 120 volts, 17" overall length.

**PROCESS
TECHNOLOGY**